

**RONAN MEALLY CONSULTING ENGINEERS  
1 CITY WALL,  
JAMES STREET  
KILKENNY**

**PROPOSED EXTENSION  
ACDAL CRECHE  
ALLENWOOD  
CO KILDARE**

**MECHANICAL SERVICES  
CONTRACT SPECIFICATION**

**T1**

**TABLE OF CONTENTS**

**1. INTRODUCTION ..... 4**

**2. CONTRACT PRELIMINARIES ..... 5**

2.1 General ..... 5

2.1.1 Responsibility : ..... 5

2.1.2 Currency Of Documents: ..... 6

2.1.3 The Site ..... 7

2.1.4 Mechanical Sub-Contractor's Visit To The Site: ..... 7

2.1.5 Site Conditions: ..... 7

2.2 The Works ..... 8

2.3 Design Drawings: ..... 10

2.4 Tender Return ..... 10

2.4.1 Interpretations ..... 11

2.4.2 Discrepancies ..... 11

2.4.3 Dimensions ..... 11

2.4.4 Standards, Codes & Authorities ..... 11

2.4.5 Quality of Equipment and Materials ..... 11

2.4.6 Equipment Mounting ..... 12

2.4.7 Alternatives ..... 12

2.4.8 Passing or Approvals ..... 12

2.4.9 Safety of Installation ..... 12

2.4.10 Maintenance of Installation ..... 12

2.4.11 Existing Services ..... 12

2.4.12 Certificates and Payments ..... 13

2.4.13 Guarantees and Warranties ..... 13

2.4.14 Defects Liability ..... 13

2.4.15 CE Marking ..... 13

2.5 Related work by Other Trades ..... 14

2.5.1 Builders Works ..... 14

2.5.2 Services Demarcations ..... 14

2.6 Contract Documentation Delivery ..... 14

2.7 Testing and Commissioning ..... 16

2.7.1 Testing and Setting to Work ..... 16

2.8 Construction Programme And Co-Ordination ..... 17

2.8.1 Programme ..... 17

2.8.2 Sequence of Construction ..... 17

2.8.3 Submissions for Acceptance Or Approval ..... 17

2.8.4 Availability Of Named Goods And Materials ..... 17

2.8.5 Availability Of Utilities And Service Supply Companies ..... 17

2.8.6 Bulk Ordering ..... 18

2.8.7 Specialist Trades ..... 18

2.9 Drawings ..... 18

2.9.1 Construction Drawings ..... 18

2.9.2 Working Drawings ..... 18

2.9.3 As Built Drawings ..... 18

2.9.4 Co-ordination and Co-ordination Drawings ..... 19

2.10 Temporary Services ..... 19

2.11 Labour ..... 20

2.11.1 General ..... 20

2.11.2 Personnel ..... 20

2.11.3 Working Hours ..... 20

2.11.4 Removal of Workmen from Site ..... 20

2.11.5 Commencement of Work ..... 20

2.11.6	Day works .....	20
2.11.7	General Obligations .....	21
1.1.1.1	Tax Clearance Procedures .....	21
1.1.1.2	Insurances .....	21
1.1.1.3	Fixed Price Contract Sum .....	22
2.12	Safety, Health and Welfare at Work .....	23
2.12.1	General .....	23
2.12.2	Safety Statement .....	23
2.12.3	Safety Rules .....	23
2.12.4	Security and Protection .....	23
2.13	Site/ Progress Meetings .....	24
2.14	Execution of Works .....	24
2.15	Protection of Property, Trespass and Nuisance .....	24
2.15.1	Protection of Existing Services .....	24
2.15.2	Protection of Works .....	24
2.16	Suppression of Noise .....	25
2.17	Order of Works .....	25
2.18	Priced Bill of Quantities: .....	25
2.18.1	Ascertainment of Prices for Variations: .....	25
2.19	COVID-19 .....	25
<b>3.</b>	<b>SCOPE OF WORKS .....</b>	<b>26</b>
3.1	General .....	26
3.2	Mechanical Sub-Contractors Responsibilities .....	26
3.3	Design Criteria .....	27
3.3.1	Internal Temperatures .....	27
3.3.2	Noise Criteria .....	27
3.4	Heating Installation .....	28
3.4.1	Pipe-work .....	28
3.4.2	Pipework Supports .....	29
3.4.3	Thermal Insulation .....	29
3.4.4	Pipe-work Identification .....	31
3.4.5	Radiators .....	32
3.5	Water Services .....	40
3.6	Above Ground Drainage .....	42
3.6.1	General .....	42
3.6.2	Pipework .....	42
3.7	Gas Services .....	<b>Error! Bookmark not defined.</b>
3.7.1	Gas Pipework .....	<b>Error! Bookmark not defined.</b>
3.7.2	Gas Detection .....	<b>Error! Bookmark not defined.</b>
3.8	Fire Systems .....	43
3.9	Control System .....	44
3.9.1	General .....	44
3.9.2	Low Temperature Hot Water .....	45
3.9.3	Indication on the Panel .....	45
3.9.4	Control Philosophy .....	<b>Error! Bookmark not defined.</b>
<b>4.</b>	<b>BUILDERS WORK AND PROTECTION .....</b>	<b>46</b>
<b>5.</b>	<b>HANDOVER/ OPERATION AND MAINTENANCE DOCUMENTATION .....</b>	<b>46</b>
<b>6.</b>	<b>MILESTONE DATES .....</b>	<b>46</b>
	<b>DATA SHEETS .....</b>	<b>47</b>
	<b>TECHNICAL DATASHEET NO. 01 PIPING AND INSULATION .....</b>	<b>48</b>

---

TECHNICAL DATASHEET NO. 02 VALVES .....	49
TECHNICAL DATASHEET NO. 03 CONTROLS .....	50
TECHNICAL DATASHEET NO. 04 RADIATORS .....	51
TECHNICAL DATASHEET NO. 05 CIRCULATING PUMPS.....	52
TECHNICAL DATA SHEET NO. 06 FIRE EXTINGUISHERS AND BLANKETS.....	53
TECHNICAL DATA SHEET NO. 07 2-PORT VALVES.....	54
TECHNICAL DATA SHEET NO. 08 HEAT PUMP .....	55
TECHNICAL DATA SHEET NO. 09 BUFFER VESSEL ... ERROR! BOOKMARK NOT DEFINED.	
TECHNICAL DATASHEET NO. 10 BOILERS..... ERROR! BOOKMARK NOT DEFINED.	
TECHNICAL DATASHEET NO 11. FILL & PRESSURISATION UNIT & DIRT AIR SEPARATOR & DOSING POT 57	
TENDER RETURN FORMS .....	62
SECTION A: FORM OF TENDER.....	63
FORM OF TENDER.....	63
SECTION C: SCHEDULE OF MATERIALS COSTS AND ALTERNATIVES.....	64

---

## 1. INTRODUCTION

This Specification specifically relates to the Mechanical Building Services and must be read in conjunction with the rest of the General Specifications, drawings and particularly the Conditions of Tendering in the Main Contract Document including Conditions of Contract, Preliminaries, Quality and general requirements, and other relevant sections of the Architect's Specification.

The Main Contract Preliminaries are included in the Appendix for your information.

**THE MECHANICAL CONTRACT WORKS SHALL BE THE MAIN CONTRACTOR**

## 2. CONTRACT PRELIMINARIES

### 2.1 General

The following initials, words and phrases shall have the following meanings:

- (i) IS - Irish Standard Specification.
- (ii) BS (EN) - British, European Standard Specification.
- (iii) CP - Standard Code of Practice.
- (iv) CIBSE - Chartered Institution of Building Services Engineers.

'The Works' - The whole of the Works envisaged by this Contract including the works of All Nominated Sub-contractors or Suppliers, Local Authority and Utilities Providers unless specifically stated otherwise.

The work - That part of the Works dependent upon or subsequent to the statement.

'Instruction' - Instruction by the Architect or Engineer.

'Inspected' - Inspected by the Architect or Engineer.

'Submitted' - Submitted to or submit to the Architect or Engineer.

'Engineer' - Refers to the Mechanical Consulting Engineer.

'Agreement', 'Acceptance', or 'Approval' by the Architect or Engineer shall have the following limitations:

(a) When given in respect to samples of materials, workmanship or methods of construction submitted in accordance with the requirements of the Specification, shall not be interpreted as denoting any degree of satisfaction with the materials used in, or the execution of the Works.

(b) When given in respect of Drawings, documents, or schemes called for by the Specification or proposed by the Mechanical Sub-Contractor is only for conformance with the design concept and design information given in the Contract Documents or contained in subsequent Architect or Engineer 's Instructions.

#### 2.1.1 Responsibility

:

Any Approval, Agreement or Acceptance by the Architect or Engineer shall have no effect unless given in writing. No such Approval, Agreement or Acceptance shall in anyway relieve or diminish the obligations of the Mechanical Sub-Contractor under this Contract.

**2.1.2 Currency**

**Of**

**Documents:**

All publications referred to shall be the latest edition thereof, together with any amendments current ten days before the date fixed for the return of Tenders.

---

### 2.1.3 The Site

Description of The Site And The Anticipated Ground Conditions:

The site is located at: **Allenwood, Co. Kildare**

The Mechanical Sub-Contractor shall verify with the Public and Statutory Authorities and others the extent and location of all their buried, surface and aboveground services, which may be affected by the Works.

### 2.1.4 Mechanical Sub-Contractor's Visit To The Site:

The Mechanical Sub-Contractor shall at the time of tendering, make himself familiar with the nature of the building construction and the site.

A site visit is highly advisable in order to view the existing building services and the scope of work contained therein.

The Mechanical Sub-Contractor shall contact the Architect to make arrangements for a site visit.

No claims resulting from failure to do so will be considered.

Architects/Structural/Mechanical and Electrical Drawings will be made available for examination to view only at their respective offices for the Mechanical Sub-Contractor upon request.

### 2.1.5 Site Conditions:

The Mechanical Sub-Contractor will be deemed to have visited the site and assessed for himself the nature of the ground and water conditions, materials to be excavated, access and any other features which may affect his programme or methods of carrying out the Works.

The Mechanical Sub-Contractor shall immediately notify the Architect or Engineer should conditions encountered on the site be significantly different from those generally described in the Contract Documents.

## 2.2 The Works

This contract document outlines the scope of the mechanical works to be carried out in the proposed extension to ACDAL Creche Building, Co Kildare.

The intention is to install a monobloc heat pump to provide the first line of heat source for the Client extension space heating. The works also involve connecting into the existing LPG boiler system and controls.

A full control philosophy shall be installed, including BMS system that will provide automatic control, based on external temperature conditions.

Architectural Drawings including site layouts, sections, elevation and plans have been included for your information.

This Specification, Documents and drawings detail the work to be carried out by the appointed Mechanical Sub-Contractor for this project.

This includes, but is not limited to, the following main areas: -

- Supply and installation of new R290 heat pump system and associated valves, fittings, buffer vessels, pipework, insulation etc.
- Supply and installation of buffer vessel including all associated fittings, valves, supports etc.
- Low loss header including all pipework, insulation, valves, fittings etc as required.
- Supply and installation of necessary expansion vessels and new pressurisation and fill unit.
- Installation of a new LPHW underfloor heating circuits complete with pipe-work, fittings, valves, manifolds, insulation and controls to service the new extension.
- Installation of a new variable speed heating circulation pumps as per the mechanical schematic drawing.
- MCC panel for operation and control of all new systems including but may not be limited to; pumps, heat pumps, 2-port valves etc.
- New hot and hot return distribution pipework and associated connections, and valves etc.
- Supply and installation of a new cold water storage, booster pump, all associated valves, fittings, supports and controls.
- Supply and installation of a ventilation system & all associated Ductwork, fittings, supports and controls.
- Testing, commissioning and setting to work the complete mechanical services package.
- Installation of all controls related equipment by the Mechanical Sub-contractor.

- Production of As-Built Drawings and Operation and Maintenance Manuals

The appointed Mechanical Sub-Contractor shall be responsible for the supply and installation of all mechanical equipment shown and / or described in this document, on the data sheets or on the drawings. The installation shall be in accordance with the general specification.

The Mechanical Sub-Contractor shall include for all supports, brackets, hangers, etc necessary for the above installation.

All mechanical motors and valves associated with the Mechanical Package shall be supplied and installed by the Mechanical Sub-Contractor.

The Mechanical Sub-Contractor shall supply the Electrical Sub-Contractor with all the necessary information as required to enable the Electrical Sub-Contractor to obtain suitable equipment and adequately cable the installation.

The Mechanical Sub-Contractor shall supply all necessary wiring diagrams of control equipment and all other plant supplied by him.

All works shall be carried out in accordance with This Document, the General Specification, the Drawings and Data Sheets.

Any discrepancies between the Specification and Drawings must be brought to the attention of the Engineer.

The Mechanical Sub-Contractor shall make no assumptions. Variations as a result of assumptions will not be paid. Requests for Information (RFI's) must be issued to the engineer.

The Mechanical Sub-Contractor shall be responsible for the complete controls installation associated with the Mechanical Package. The electrical work and cabling to equipment, plant, motors, etc. including local isolators to all relevant mechanical equipment shall be carried out by the Electrical Contractor.

The Mechanical Control Panel(s) shall be supplied and installed by the Mechanical Sub-Contractor.

The Mechanical Sub-Contractor shall supply and install valves etc. required to enable the Electrical Sub-Contractor to complete the electrical installation. The Mechanical Sub-Contractor shall install all mechanical controls equipment issued to him by the Controls Specialist.

The Controls Specialist shall supply all control related devices required to complete the controls installation. The Controls Specialist shall be a Sub-Contractor to the Mechanical Sub-Contractor.

The Electrical Sub-Contractor shall be responsible for making all final electrical wiring and control wiring terminations.

## 2.3 Design Drawings:

The Mechanical Design Drawings shall be read in conjunction with all relevant Specifications. These drawings have been issued to in AutoCAD 2013 format in pdf. Specifications have been issued to you also in pdf.

If you have problems opening or reading this CD please contact our office immediately. No contact will be taken as understood that all documents have been received in good order and can be viewed.

A full set of all structural and architectural design drawings, documentation and copies of any revised design drawings shall be obtained from the Architect or Engineer.

Revisions to design may be in the form of sketches and the Mechanical Sub-Contractor shall not rely on these changes being available in CAD format.

It is recommended that the Mechanical Sub-Contractor shall obtain a complete set of Architectural/Mechanical/Electrical and Structural Drawings to assist in completing this Tender.

One set of Mechanical Services Design Drawings can be issued to the Mechanical Sub-Contractor but will be charged at a rate of €3 per A1 drawing.

## 2.4 Tender Return

The Mechanical Sub-Contractor shall be deemed, before tendering, to have made a thorough examination of the Drawings, Specifications, Conditions of Contract, the Site and other things affecting the proposed works to ascertain precisely the nature and extent of same and the conditions under which the proposed works will have to be executed.

The Mechanical Sub-Contractor shall be deemed to have obtained full information on all matters which could in any way influence this Tender.

The Tender Return Form at the back of this document shall be completed and returned with the Tender in accordance with the cover letter included with this tender.

The Tenderer shall identify as shown, the various elements within the Tender. Elements should not be grouped together.

The Tenderer shall also refer to the General Requirements in Conditions of Tendering in the Main Contract Document.

All Tender Documents, Data Sheets and Drawings should be returned along with the Tender Return Form to the offices above.

#### 2.4.1 Interpretations

In the Contract, except where the context otherwise requires, "give notice", "submit", "supply", "furnish", and similar expressions shall mean give notice, submit, supply, furnish and the like to the Architect/Engineer.

#### 2.4.2 Discrepancies

When this section is at variance with any other sections of the tender documents the Tenderer shall obtain clarification before tendering.

Failure to do so will be deemed to imply that the most onerous requirements have been included for.

#### 2.4.3 Dimensions

All Dimensions abstracted from the Mechanical Services Design Drawings should be verified both on Site and with the Architect's drawings.

#### 2.4.4 Standards, Codes & Authorities

All work shall meet all the Requirements of National and Local Statutory Authorities and shall be in accordance with, and not limited to, the following: -

1. Irish Building Regulations 2000 and Amendments.
2. Gas Board Regulations.
3. All Applicable Irish, British and European Standards.
4. All Health and Safety Authority Requirements.
5. All Local Council Rules and Regulations.
6. CIBSE - Chartered Institution of Building Services Engineers -
7. Safety, Health and Welfare at Work Act, 1989.

#### 2.4.5 Quality of Equipment and Materials

All equipment and materials shall be new unless otherwise noted.

Unless otherwise specified, all materials, plant and equipment, and the installation thereof, shall comply with the Irish Standards and Codes of Practice, Institutional Regulations, Statutory Requirements, National and Local By-laws where applicable. Allow for proper packaging and delivery of all equipment and materials and for returning re-useable packaging to the suppliers as appropriate.

Allow for proper storage and protection of all equipment and materials on Site. Workmanship shall be of the best quality and shall be produced by skilled and responsible craftsmen fully experienced in their respective trades.

---

All equipment shall be installed only to manufacturer's recommendations.

#### **2.4.6 Equipment Mounting**

Insert a damp proof membrane wherever metal comes into contact with concrete, including all mechanical equipment, supports etc.

#### **2.4.7 Alternatives**

The Equipment and Plant Priced in the Tender Return must reflect those specified in the Datasheets. Alternatives may be identified on the Alternative Equipment Schedule provided in the Datasheets.

#### **2.4.8 Passing or Approvals**

The Passing or Approval of any aspect of 'the Works' by the Architect/Engineer does not relieve the Mechanical Sub-Contractor of his responsibility under this contract to provide the specified systems, plant and equipment.

Any works or materials deemed unsatisfactory and/or not in compliance with the intent of the Specification and documents shall be removed and replaced with satisfactory work and materials at the Mechanical Sub-Contractor's cost.

The Mechanical Sub-Contractor shall issue details of all specified equipment and plant for approval prior to placing order.

All equipment and plant shall be approved on site by the engineer prior to installation.

#### **2.4.9 Safety of Installation**

The Installations shall in all events operate in "fail-safe" mode i.e. if there is a failure or malfunction of a piece of plant or equipment, a consequential dangerous situation shall be prevented by automatic control. All necessary devices and interlocks shall be allowed for in the Tender whether specified in detail or not.

#### **2.4.10 Maintenance of Installation**

The Mechanical Services Installations shall be installed such that all components of the Installations are accessible and easily maintainable.

Factory trained service networks shall support all equipment used in the Installations. All spare parts shall be available factory ex-stock for a period of 5 years from purchase date.

#### **2.4.11 Existing Services**

The Mechanical Sub-Contractor shall be responsible for ensuring that all existing services on the site, such as gas, communications, water and electricity are undamaged during the works.

The Mechanical Sub-Contractor shall be liable for any compensation claimed by unrelated parties in the event of an inadvertent break in the existing services that occurs as a result of the construction work.

---

**2.4.12 Certificates and Payments**

The Mechanical Sub-Contractor shall refer to the Certificates and Payments Clauses of the Main Contract Document.

The Mechanical Sub-Contractor must submit Detailed Progress Statements for each Claim and Interim Certificate Amounts may be at the Engineer's Discretion.

**2.4.13 Guarantees and Warranties**

All manufacturers guarantees and warranties on plant, equipment, etc., shall be valid up to the end of the Defects Liability Period.

**2.4.14 Defects Liability**

Refer to the Conditions of Tendering in the Main Contract Document.

**2.4.15 CE Marking**

All electrical equipment, systems supplied and installed shall conform to the appropriate EU Directives and shall carry the applicable CE Marking.

## 2.5 Related work by Other Trades

### 2.5.1 Builders Works

The specialist contractor shall insure that the main contractor has allowed provision to accommodate all the attendances and builders work requirements of the specialist contractors.

Otherwise the specialist contractor must include for the works. No variations costs will be entertained in relation to the above.

All builders' work such as cutting of holes in walls and floors (of size greater than 100mm in any dimension) the provision of foundation for plant and machinery, etc., will be carried out by the Main Contractor. The Mechanical Sub-Contractor shall, however, be responsible for the correct marking out and providing all builder's works information/drawings to enable the Main Contractor to fulfil his obligations with regard to  
Builder's  
Attendances.

The Mechanical Sub-Contractor shall produce Builder's Work Drawings and submit to the Engineer for comment and submit to the structural engineer for approval.

Where services pass through partitions (floors, walls, ceilings) the Mechanical Sub-Contractor shall maintain the fire rating if applicable within the services e.g. Fire dampers in ductwork etc. The Mechanical Sub-Contractor shall refer to the Architect to identify all Fire Walls within the building.

The Main Contractor shall be responsible for making good of all builder's work opes around services and ensuring that the making good does not damage the services installed.

Work to be carried -

- Safe Disposal of construction/debris
- Lifting/Hoisting or major mechanical plant only
- Trenches for incoming Gas/water and outgoing drainage
- Excavating/Backfilling of all trenches as identified.
- OPES for passage of pipe work and ductwork above 100mm diameter or square
- Fire stopping and filling of OPES
- Painting of exposed pipe-work

### 2.5.2 Services Demarcations

Definition of demarcations shall not absolve responsibility of the Mechanical Sub-Contractor to perform the whole of the Contract works in a manner satisfactory to the Architect/Engineer.

## 2.6 Contract Documentation Delivery

The Mechanical Sub-Contractor shall allow for supplying copies of all Mechanical Services RFI's (Request For Information), Drawings and any other Mechanical Services Documentation directly to the Architect/Engineer.

This flow of information shall be simultaneous to all parties.

A4 information may be faxed.

Overnight courier should send all other information over the size of A4.  
All costs for this delivery process shall be included in the contract sum.

## 2.7 Testing and Commissioning

The Mechanical Sub-Contractor shall ensure that sufficient time is allowed in the Main Contractor's programme to carry out the testing, pre-commissioning and handing over of the installation. The Mechanical Sub-Contractor shall engage one of the following Specialist Testing and Commissioning Firms to undertake the commissioning of the entire mechanical services installation, to include all air balancing and water balancing:

### **Spectrum Engineering**

Unit 6 117 Baldoyle Ind Est  
Dublin 13  
Tel: 01 8398994  
Fax: 01 8398381

### **SIBS,**

Unit 18, Bluebell Business Park,  
Old Naas Road,  
Dublin 12

Tel 01 4291300

The Mechanical Sub-Contractor shall ensure that the Specialist Commissioning firm shall be given at least two week within the main contractors programme to complete the commissioning process.

The Mechanical Sub-contractor shall furnish the Engineer with the report, as completed by the Specialist Commissioning Firm.

### 2.7.1 Testing and Setting to Work

On completion of works or parts of the works the Mechanical Sub-Contractor shall test the various installations in accordance with standard test procedures set out in the I S, BS and European Standards and Codes of Practices.

The various sections may not all be carried out together and the Mechanical Sub-Contractor shall include in the contract sum for testing phases to suit the progress of the building.

Where nominated suppliers appointment includes for testing, the Mechanical Sub-Contractor shall be responsible for ensuring that all tests are properly carried out and test/commissioning certificates to be included in the O & M Manuals.

The Mechanical Sub-Contractor shall serve at least seven days notice on the Engineer before carrying out the test to allow the Engineer or his representative to witness the test if he so wishes.

Nevertheless the Mechanical Sub-Contractor shall forward to the Engineer fully completed and signed Test Certificates for all installation works.

## **2.8 Construction Programme And Co-Ordination**

### **2.8.1 Programme**

The Mechanical Sub-Contractor shall include within his Programme, details of his intended timing and order for the construction of the Mechanical Services Works and the dates by which any significant items of information will be required from the Main Contractor.

The Programme shall make all necessary allowances for submissions and Approvals and any other specific requirements of the Specification, including allowances for any standing time and time for work under provisional and contingency sums, which may affect the progress and shall be arranged such that actual progress may be recorded against each item.

The Programme shall indicate the start dates and times on site for the various utilities and service supply companies whose works the Main Contractor is responsible for co-ordinating.

### **2.8.2 Sequence of Construction**

The Mechanical Sub-Contractor shall submit in writing his proposals for the sequence of construction, diversions, connections and reconnections before the work begins. Where a sequence of construction is described or shown on the drawings or other schedules the Mechanical Sub-Contractor may, if he so wishes, submit his own proposals not less than two weeks before the work begins.

### **2.8.3 Submissions for Acceptance Or Approval**

Where submissions for Approval are specified, the Mechanical Sub-Contractor shall prepare and submit with his Programme a schedule of such submissions, co-ordinated with the Programme and including agreed time allowances for submission and Approval before the related work commences.

Working Drawings and Calculations to support details and components chosen and any other relevant information shall be submitted not less than two weeks before manufacture begins.

The Mechanical Sub-Contractor shall check that all Working and Installation Drawings are complete and co-ordinated.

The Mechanical Sub-Contractor shall confirm in writing to the Main Contractor and Engineer that he has done so.

### **2.8.4 Availability Of Named Goods And Materials**

Within two weeks of the commencement of the Contract the Mechanical Sub-Contractor shall determine the availability of all named goods and materials specified in the Contract Documents, and shall notify the Main Contractor and Engineer of his findings in writing.

### **2.8.5 Availability Of Utilities And Service Supply Companies**

Within two weeks of commencement of the Contract the Mechanical Sub-Contractor shall determine the availability of all relevant Utilities and service supply companies detailed in the contract documents, and shall notify the Main Contractor and Engineer of his findings in writing.

### **2.8.6 Bulk Ordering**

Bulk orders for materials shall not be placed before any Approvals required by the Specification for sources and samples have been given, or satisfactory results of any preliminary tests required by the Specification have been submitted.

### **2.8.7 Specialist Trades**

The Mechanical Sub-Contractor shall ensure that specialist trades responsible for work necessary for the proper execution of the works or for related work, are present on site when required.

The Mechanical Sub-Contractor shall ensure that all units, components or assemblies are available in time for incorporation in the Works.

## **2.9 Drawings**

### **2.9.1 Construction Drawings**

The Mechanical Sub-Contractor shall check all Drawings and Specifications to ensure in good time that he has sufficient information to carry out the work and that all the instructions, Drawings and Specifications he has been provided with compatible information on the work to be carried out.

If the Mechanical Sub-Contractor considers additional details are required, he shall notify the Main Contractor and Engineer immediately.

In the event of any discrepancy being found between such Drawings and Specifications, the Mechanical Sub-Contractor shall notify the Main Contractor/ Engineer immediately.

### **2.9.2 Working Drawings**

The Mechanical Sub-Contractor shall keep on site a full set of the Construction Drawings, on which he shall record and note the actual layout of all the mechanical services installations as installed, including routes.

The Mechanical Sub-Contractor shall show all pipe work and ductwork routes and final locations of equipment and outlets on his Working Drawings, which he will submit to the Engineer for appraisal prior to installation.

The Mechanical Sub-Contractor shall record all alterations, variations, additions and omissions.

The Mechanical Sub-Contractor shall include the contract sum for the maintenance of up to date working drawings on site during the course of the project.

### **2.9.3 As Built Drawings**

The Mechanical Sub-Contractor shall include for the preparation of final marked-up drawings, at practical completion stage.

The drawings shall be completed in current CAD format and accurately show all equipment/plant locations and mechanical service routes.

---

The Mechanical Sub-Contractor shall on completion, submit to the Engineer a draft copy of the full complement of As-Built Drawings and allow two weeks for comment of same.

#### **2.9.4 Co-ordination and Co-ordination Drawings**

The Mechanical Sub-Contractor shall produce a Co-ordinated set of Mechanical and Electrical plans identifying the Co-ordination of all Services.

The Mechanical Sub-Contractor shall work closely with the Electrical Sub-Contractor to provide such Drawings in A1 format.

The Mechanical sub-contractor shall make due allowance in his tender to prepare co-ordination drawings using mechanical and electrical drawings and structural drawings.

All runs and locations will generally be as shown on the Mechanical & Electrical Services Drawings, but changes shall be effected when and as required to co-ordinate with other trades.

No allowances will be made to the Mechanical Sub-Contractor for changing of work built-in or fabricated, that conflict with other trades.

The Mechanical Sub-Contractor must co-ordinate and must work in close co-operation with all the other Contractors/Tradesmen to determine runs and locations free from interference, prior to installation.

#### **2.10 Temporary Services**

It is the responsibility of the Main Contractor to provide adequate temporary water, power and lighting supply for the duration of the Construction period.

The Mechanical Sub-Contractor may enter into an agreement with the Main Contractor to provide these services, the payment of which will be made by same.

Adjustment to the Contract sum will only be considered for alteration in works to be done, in excess of normal requirements for temporary mechanical services required for construction.

## **2.11 Labour**

### **2.11.1 General**

The Mechanical Sub-Contractor shall ensure that all employees are registered for PAYE / PRSI.

The Mechanical Sub-Contractor shall provide all necessary evidence to confirm the qualifications and competence, of any workmen to be employed on the works.

If so requested by the Project Manager/Architect, the Mechanical Sub-Contractor shall provide a written List of all personnel proposed to be employed on the works.

The Mechanical Sub-Contractor shall ensure that all employees have successfully completed a SafePass course

### **2.11.2 Personnel**

The Mechanical Sub-Contractor shall at all times provide sufficient and adequate numbers of skilled men and labourers to carry out and maintain each and every part of the Works in a proper and expeditious manner, and shall provide all materials, tools, equipment, plant and everything necessary for the proper execution, completion and maintenance of the Works.

### **2.11.3 Working Hours**

The Mechanical Sub-Contractor shall allow for executing any work, which, in the Project Manager/Architect's opinion is likely to cause annoyance or inconvenience to occupants in the vicinity, at such times during normal working hours as the Project Manager/Architect may direct.

The Mechanical Sub-Contractor shall not execute any work outside normal working hours without the prior written consent (Site Instruction) of the Project Manager/Architect or Engineer. Normal working hours excludes Night Work and Sundays.

### **2.11.4 Removal of Workmen from Site**

The Architect/Project Manager shall have the power without redress to have removed from Site any Workmen who misconduct themselves or who are incompetent or negligent.

### **2.11.5 Commencement of Work**

No item of work shall be commenced until satisfactory results of any related preliminary tests required by the Specification have been submitted.

### **2.11.6 Day works**

The Mechanical Sub-Contractor shall submit as part of the tender return a Schedule of Day Works as determined under the Main Contractor's Conditions of Contract, shall be

accepted as a basis for valuing work, only when the main contractor or Engineer has issued written instructions to the Mechanical Sub-Contractor to that effect.

All day works variations must be ordered or authorised by the Architect/Project Manager and accompany a valid and signed site instruction.

The Mechanical Sub-Contractor shall submit to the Main Contractor and Engineer an application for all day works due at the end of each month together with day-works record sheets which must be signed by the Architect/Project Manager to verify the day-works has been completed.

Valuation Certificates shall support application for payment for the month, which have been certified by the Engineer, or a representative. Such endorsement shall be deemed to certify that the labour, materials and plant used are correct.

Day work Valuation Certificates shall give the following: -

- Description of works done
- Operatives' names and trades
- Rates of wages and hours
- Insurances
- Quantities of materials used
- Details of plant used

Day-work Rates shall only apply to NEW Scope of Works NOT contained within this Contract. Tender Rates shall apply to all variations which are related to additional scope of works which is of a similar nature to that already defined in this specification and under similar site conditions.

## **2.11.7 General Obligations**

### **1.1.1.1 Tax Clearance Procedures**

The Mechanical Sub-Contractor shall be registered with the Revenue Commissioners for Income Tax purposes and shall submit with his Tender a current Sub-Contractor's C2 Certificate or a Tax Clearance Certificate.  
Failure to do so will nullify the tender.

### **1.1.1.2 Insurances**

The Mechanical Sub-Contractor shall provide for Insurance under any National or Local Statutory Acts affecting labour in force at the Tender Date (unless previously allowed for in rates), and as set out in the Main Contractor's Conditions of Contract.

The Mechanical Sub-Contractor shall comply with the provisions of the Building (Safety, Health, Welfare) Regulations under Factories Act.

The Mechanical Sub-Contractor shall provide for all payments in connection with obligations arising under Working Rule Agreements, Employment Regulation Orders, Registered Employment Agreements and the like.

The Mechanical Sub-Contractor shall provide for all payments in connection with Pensions Scheme, Guaranteed Week, Redundancy Scheme, Sick Pay Scheme and Pay Related Social Insurance (unless previously allowed for in rates).

The Mechanical Sub-Contractor shall provide for all payments in connection with conditions of employment during the Contract.

#### **1.1.1.3 Fixed Price Contract Sum**

Refer to the cover letter accompanying the tender documentation and refer to the Main Contractors preliminaries.

---

## **2.12 Safety, Health and Welfare at Work**

### **2.12.1 General**

The Mechanical Sub-Contractor shall comply fully with Safety and Health requirements as stated in the Main Contract Conditions.

In particular the Mechanical Sub-Contractor shall comply with the conditions of the Safety, Health and Welfare at Work (Construction) Regulations.

The Mechanical Sub-Contractor shall contribute as necessary to the Health and Safety Plan and File for the building and co-operate with the Project Supervisor. (T.B.A.)

### **2.12.2 Safety Statement**

The Mechanical Sub-Contractor shall submit a Contract specific Safety Statement to the Project Supervisor for Construction for review within ten (10) working days of Contract Award. The Safety Statement must be signed by the Project Supervisor (Construction).

This Statement shall set out arrangements whereby the Contractor intends to ensure the safety, health and welfare of his employees and shall include a list of foreseeable hazards, assessment of risks and proposed control measures.

### **2.12.3 Safety Rules**

The Mechanical Sub-Contractor shall observe and ensure full implementation by his employees of the Safety Rules as specified on site by the Main Contractor.

### **2.12.4 Security and Protection**

On the grounds of Client Security, maps, plans, drawings and sketches, etc of the works should be treated as highly confidential and only be released to other persons on a need to know basis.

Refer to the Main Contract Documents for any specific requirements for this site.

No photography is allowed on site without prior written consent from the Client.

Any special security clearance to be approved by the Client.

---

### **2.13 Site/ Progress Meetings**

The Mechanical Sub-Contractor will be obliged to attend all site/ progress meetings, as required and determined by the Main Contractor/Engineer.

### **2.14 Execution of Works**

The whole of the Works shall be executed in the manner specified and to the dimensions and in accordance with the particulars shown on the drawings or given in the Specification's.

The Mechanical Sub-Contractor shall be paid only for the work executed to the satisfaction of the Architects/Engineer.

The Works shall be executed and maintained in an Approved and workmanlike manner, by workmen skilled in the various trades required for carrying out and maintaining the Works.

All materials, which are used in connection with the Works, shall be of the best quality of their respective kinds.

### **2.15 Protection of Property, Trespass and Nuisance**

The Mechanical Sub-Contractor shall take every precaution to preserve from damage any property; trees and shrubs etc, situated on or near the Site of the Works and shall indemnify the Client against all claims in connection thereto.

The Mechanical Sub-Contractor and Suppliers shall keep within the Site Boundaries And shall not Trespass or cause Nuisance to adjoining Operations / Property or the Public generally.

#### **2.15.1 Protection of Existing Services**

The Mechanical Sub-Contractor shall make good, at his own expense any damage caused whatsoever to existing services to the complete satisfaction of and in accordance with the instructions of the Engineer/Statutory Authority concerned, and shall keep the Client indemnified at all times from claims in connection with the damage.

#### **2.15.2 Protection of Works**

The Mechanical Sub-Contractor shall carefully cover up or otherwise protect all work liable to injury from the weather, stormwater, or any other cause during construction.

The Mechanical Sub-Contractor shall allow for any contingencies or extra temporary works which may be necessitated by adverse site conditions or which may be required by the Engineer or Architect for the protection of the Works.

## 2.16 Suppression of Noise

The Mechanical Sub-Contractor shall have due regard at all times for the need to reduce the noise level of plant to a minimum.

This is particularly necessary where work is carried out in close proximity to hospitals, Clients, and housing and office developments.

Compressors and all other plant, which is likely to constitute a nuisance or cause distress, must be fitted with efficient silencing devices.

## 2.17 Order of Works

The Mechanical Sub-Contractor shall, within two weeks of the date of the official order to commence the Works, submit to the Main Contractor, for his Approval, a detailed programme setting out the stages and order in which he proposes to carry out and complete the Works within the prescribed time for completion.

## 2.18 Priced Bill of Quantities:

The successful Mechanical Sub-Contractor will be required to submit to the Engineer a comprehensive priced Bill of Quantities on which this tender is based.

Failure to submit a priced Bill of Quantities will nullify his/her appointment.

### 2.18.1 Ascertainment of Prices for Variations:

Any oral instructions, directions or explanations given by the Architect or Engineer upon the Works to Mechanical Sub-Contractor shall if involving a variation be confirmed in writing by the Mechanical Sub-Contractor to the Architect or Engineer within five working days.

The rates in the Priced Bill of Quantities referred to in the clause above applied to the Works shall determine the value of work carried out as a variation when such work is of a character similar to that to which the aforesaid rates apply and is carried out under similar conditions.

The aforesaid rates shall also determine the value of any work omitted.

## 2.19 COVID-19

The tenderers shall allow in their tender for working on site in line with the CIF's Standard Operating Procedure (SOP) and allow in the tender, where indicated, for any additional time and cost incurred to accommodate the imposition of COVID-19 restrictions.

Ensure all directly and indirectly employed staff have undergone the CIF's COVID-19 Safety Induction Programme and have a digital card.

It should also be ensured that all staff follow the instructions of the main contractor's COVID-19 compliance officer at all times.

### 3. SCOPE OF WORKS

#### 3.1 General

#### **The mechanical contract works shall be domestic to the main contractor**

In all sections of this Specification, the word “Mechanical Sub-Contractor” shall mean the tenderer whose tender has been accepted for the Mechanical Building Services Installation.

#### 3.2 Mechanical Sub-Contractors Responsibilities

The tenderer must at the time of tender, state the manufacturers names and catalogue numbers of the equipment on which his tender is based.

It is not sufficient for the tenderer to state “materials as specified “, the information given must be adequate to identify the actual unit concerned without ambiguity.

The Mechanical Sub-Contractor shall study carefully the furniture layouts before commencing the marking out of installations in any room.

Any obstructions to the proper positioning of the outlets shall be brought to the notice of the Engineer.

The Mechanical Sub-Contractor shall keep a competent supervisor constantly on the works at all times when the Contract Works are been carried out. The supervisor must be authorised to receive instructions on behalf of the Mechanical Sub-Contractor.

The Mechanical Sub-Contractor shall be entirely responsible for the Contract works, whether under construction or during testing and commissioning, until the Works have been accepted as been completed by the Engineer. The Engineer reserves the right to reject any workmanship and materials not conforming to the specification and instruct the Mechanical Sub-Contractor to carry out such alterations or replacements of materials at the Mechanical Sub-Contractor’s expense.

When the installation has been completed in accordance with the Contract, a Completion Certificate will be issued certifying the date on which the installation was taken over and the commencement of the maintenance/ defects liability period.

### 3.3 Design Criteria

#### 3.3.1 Internal Temperatures

Design values for dry resultant and relative humidity are published in table 1.1 of Guide A, Environmental Design, published by the Chartered Institute of Building Services Engineers (CIBSE). These values will be adopted and are as follows:

Classrooms and Offices	18-21 °C, (winter heating only) relative humidity uncontrolled
Entrance Halls/Lobbies;	19-21 °C, (winter only) relative humidity uncontrolled
Corridors	19-21 °C, (winter only) relative humidity uncontrolled
Toilets;	19-21 °C, (winter) relative humidity uncontrolled

#### 3.3.2 Noise Criteria

The following noise criteria are proposed for the difference space. The mechanical systems will be designed to meet these noise criteria. These noise criteria have been obtained from CIBSE Guide A, Environmental Design, published by the Chartered Institute of Building Services Engineers.

Area	Noise Rating in the Space, NR
Classrooms and Offices	35
Entrance Halls/Lobbies;	35 – 40
Corridors;	40

### 3.4 Heating Installation

The mechanical contractor shall supply, install, test, chemically flush, certify and commission new heating pipe work as detailed on the drawings and in the specification including, but not limited to:

- Supply and installation of new R290 heat pump and associated header, buffer vessel, pipework, valves, fittings etc
- Heat pump condenser to be installed in protective cages.
- Filling, installation of corrosion inhibitor and testing of system.
- Supply and installation of new underfloor heating pipework, circuits, two-port valves, stats, lock shield valves and necessary fittings.
- Installation of a new variable speed heating circulation pumps.
- Supply and installation of new expansion vessel and pressurisation and fill unit.
- All of the above to be complete with associated valves, pipe work, insulation, fittings and controls.
- Thermal insulation to all pipe-work as Armaflex/Kingspan Kooltherm.
- Commissioning of heating system.

**A site visit must be carried out by the mechanical contractor prior to submission of the tender return.**

All new heating pipe-work shall be insulated and metal clad within the plant room.

The mechanical sub-contractor shall make allowance for automatic air vents at all high points in the heating system.

Isolating valves must be installed by the mechanical sub-contractor to allow all items of plant and equipment to be isolated for easy removal.

**The contractor shall allow for including a corrosion inhibitor when filling the system.**

#### 3.4.1 Pipe-work

Heating pipe-work shall be manufactured from **medium grade black mild steel tube to BS 1387 un-galvanised within the boiler room.**

All pipe-work supports, guides and anchors to support and control the movement of the pipe-work, including expansion bellows, shall be supplied and installed by the mechanical contractor.

Generally, for clarity, all isolating valves to plant, fixtures and equipment are not shown on the drawings, refer to general specification.

However, isolating valves and drain cocks shall be supplied and installed by the mechanical contractor in accordance with the specification and drawings.

The Mechanical Contractor shall include for the flushing and chemical cleaning of the complete LPHW Heating System. All chemical cleaning and heating system dosing to be witnessed by the Engineer.

Pipe work to radiators will run at high level with local drops to radiators as shown on the drawings to individual radiators. Extensions pieces from radiators to the upstand pipes are not acceptable and shall not be provided. It is imperative that pipes are installed at the correct dimensions for the radiators when the floors are being poured.

Pipe work must be sleeved and insulated in such a manner that it can be fully withdrawn and reinstalled if need be post installation without disruption to the areas and finishes that it passes through.

Each teaching space and staffrooms shall be controlled via two port motorised valves with electrically powered digital thermostats with a lockable range up to a maximum of 24°C. Care should be taken when locating these units to ensure they are not easily accessible by the pupils.

**3.4.2 Pipework Supports**

Refer to General Specification

**3.4.3 Thermal Insulation**

After all hydraulic tests have been carried out on the water services installations the system shall be fully insulated. This shall include all pipes, elbow, fittings, and flanges. Pumps and valves shall be encased with insulated covers.

As a minimum all pipe-work will be insulated using mineral fibre wool and shall be finished in foil.

The thickness of insulation shall be in accordance with BS 5422: 2009; declared thermal conductivity of insulation material shall not be less than 0.035 W/mK at 40°C.

**Pipe work to be encased in concrete:**

AF Armaflex Class O, in black, shall be used. Thermal conductivity 0.033W/m2K.

Pipe Diameter mm	Thickness of Insulation mm
15	19
22 or 20	25
28 or 25	25
32	25
40	25

**All other pipe work**

Exposed pipe work or pipe work in ceiling voids, stud partitions, etc shall be thermally insulated with foil backed mineral fibre wool.

Kingspan Kooltherm FM pipe insulation, silver

Pipe Diameter	Thickness of Insulation
mm	mm
15	15
22 or 20	20
28 or 25	20
32	20
40	20

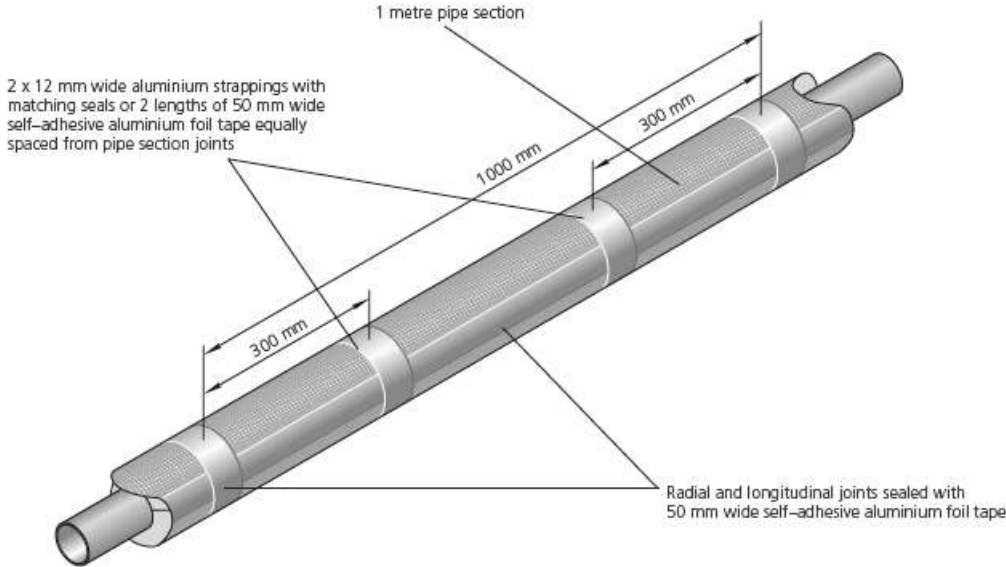
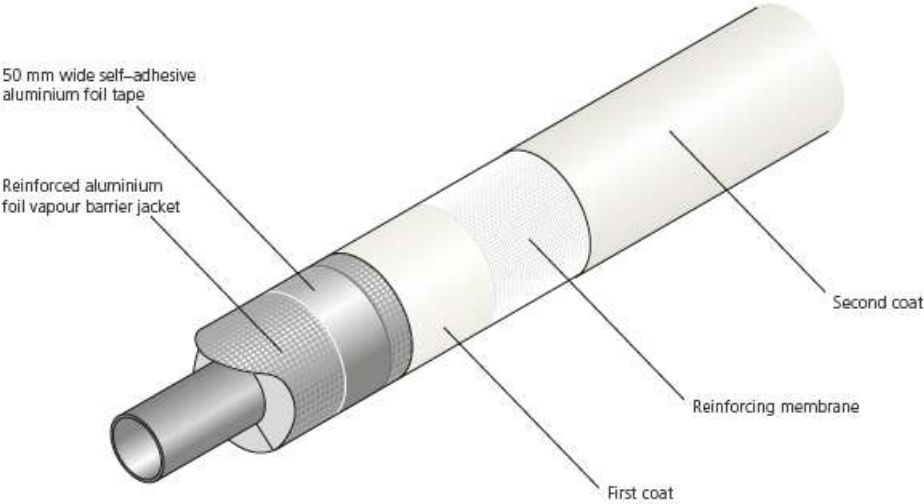

Figure E1: Application of Kooltherm™ FM Pipe Insulation



**3.4.4 Pipe-work Identification**

All isolating and control valves shall be fitted with a propriety made identification label. A Schematic drawing of A3 size shall be erected within the boiler room detailing corresponding valve numbers. Drawing to be protected by frame with transparent Perspex glass.

After the pipe-work insulation is complete, appropriate colour and direction identification labels shall be fitted at every change of direction etc to comply with BS 1710

### 3.4.5 Heat Pump

The Extension is to be fitted with 1 No 9KW Heat pump (ALL IN ONE UNIT).

The heat pump shall have a DC inverter compressor, DC inverter Fan motor, Electronic Expansion valve and gas injection circuit.

The unit fan shall have a noise level no greater than 40dB(A) at 10m from the surface of the unit and shall be a monobloc unit with integrated circulating pump, expansion vessel and frost protection.

The timeclock with boost function for heating and hot water control. This sends an enable signal to the heat pump. Mains power is permanently supplied to the heat pump to ensure frost protection is always available.

The heat pumps shall be R290 refrigerant compatible.

#### **VALVES:**

Provide and fit brass draw-off cock, to BS 2879 type A, at the lowest point of the system.

Provide and fit brass gate valve to BS 5154 to mains water feed to heating system.

Provide and fit a safety valve and drip pipe as close and practicable to the heat pump unit outlet

#### **EXPANSION:**

The Mechanical Contractor shall supply and install a 50 Litre heating water expansion vessel adjacent to the heat pump.

#### **BUFFER TANK:**

The heat pump shall be installed together with a 187 Litre cylinder with integrated 60 L buffer tank.

#### **CIRCULATION PUMP:**

The circulation pumps to be a "Grundfos" or similar and approved and supplied with the heat pump.

#### **TESTING:**

Provide for testing all pipe work and the system, to the entire satisfaction of the Engineer. All leaking pipes or fittings shall be taken out and replaced with new ones, and the whole system tested again. All tests must be attended by the Engineer or his representative.

---

Wall mounted programmable thermostats shall be installed for each zone and a central 7 day 24 hour time clock shall be installed with each manifold which will provide the enable signal to the heat pump.

The heat pump shall be installed with all necessary safety/regulation valves and pipeline equipment.

The heat pump flow temperature shall be 60°C and return temperatures shall be 50°C.

#### **3.4.6 Pumps**

All pumps shall be A-rated pumps. Pumps to be fitted to pipe-work with anti-vibration connections.

Pumps shall be installed in strict accordance with the manufacturer's instructions. Testing points to be installed on the inlet and discharge of each pump to allow testing and commissioning.

#### **3.4.7 Pipework**

Heating pipe-work to/from the heat pump shall be ALUPLEX

Heating pipe-work throughout the building shall be ALUPLEX.

All pipe-work supports, guides and anchors to support and control the movement of the pipe-work, including expansion bellows, shall be supplied and installed by the mechanical contractor.

Generally, for clarity, all isolating valves to plant, fixtures and equipment are not shown on the drawings, refer to general specification. However, isolating valves and drain cocks shall be supplied and installed by the mechanical contractor in accordance with the specification and drawings.

The Mechanical Contractor shall include for the flushing and chemical cleaning of the complete LPHW Heating System.

### 3.4.8 Underfloor Heating

All underfloor heating zones as indicated on the drawings are to be heated by an underfloor heating system, fed from the main plant primary pipework.

The underfloor heating system is to be designed and supplied by the specialist underfloor heating contractor and installed by the Plumbing & Heating contractor under his instruction.

The system to comprise coils of ultra high-density crosslinked polyethylene pipe laid in the floors and connected to manifolds in the locations specified.

The underfloor heating system is to be designed in accordance with DIN 4725, BS EN 1264, or other recognised European standards.

The underfloor heating pipework shall be crosslinked by the Engel process and shall be marked as such (PEX-a). The underfloor heating pipework shall incorporate an oxygen diffusion barrier of EVAL bonded to the outside of the PEX pipework, during manufacture.

The underfloor heating pipework shall be pigmented with a high opacity pigment to prevent ultraviolet light penetration causing microbiological growth within the circulating water.

The underfloor heating manifolds shall be of one-piece tubular construction in brass and shall incorporate balancing valves and also flow meters to each circuit, so that correct commissioning and operation of the system can be verified.

The underfloor heating system shall, with respect to the whole system (pipe, manifolds, jointing method, ancillary components) and the pipe and jointing system meet the requirements of BS 7291: Class S rating (plastic pipe suitable for connection to an unvented, pressurised heating system).

The underfloor heating system shall be covered by an insurance-backed guarantee, provided by the system manufacturer. Specimen guarantee to be provided with tender submission.

The specialist underfloor heating contractor shall prepare detailed floor coil layout drawings, for approval, prior to installation of the system.

The specialist underfloor heating contractor shall allow for one return visit to site to balance the system, once the main plant has been commissioned.

### 3.4.9 Thermal Insulation

After all hydraulic tests have been carried out on the water services installations the system shall be fully insulated. This shall include all pipes, elbow, fittings, and flanges. Pumps and valves shall be encased with insulated covers.

As a minimum all pipe-work will be insulated using mineral fibre wool and shall be finished in foil.

The thickness of insulation shall be in accordance with BS 5422: 2009; declared thermal conductivity of insulation material shall not be less than 0.035 W/mK at 40°C.

**Pipe work to be encased in concrete:**

AF Armaflex Class O, in black, shall be used. Thermal conductivity 0.033W/m2K.

Pipe Diameter mm	Thickness of Insulation mm
15	19
22 or 20	25
28 or 25	25
32	25
40	25

**All other pipe work**

Exposed pipe work or pipe work in ceiling voids, stud partitions, etc shall be thermally insulated with foil backed mineral fibre wool.

Kingspan Kooltherm FM pipe insulation, silver

Pipe Diameter mm	Thickness of Insulation mm
15	15
22 or 20	20
28 or 25	20
32	20
40	20

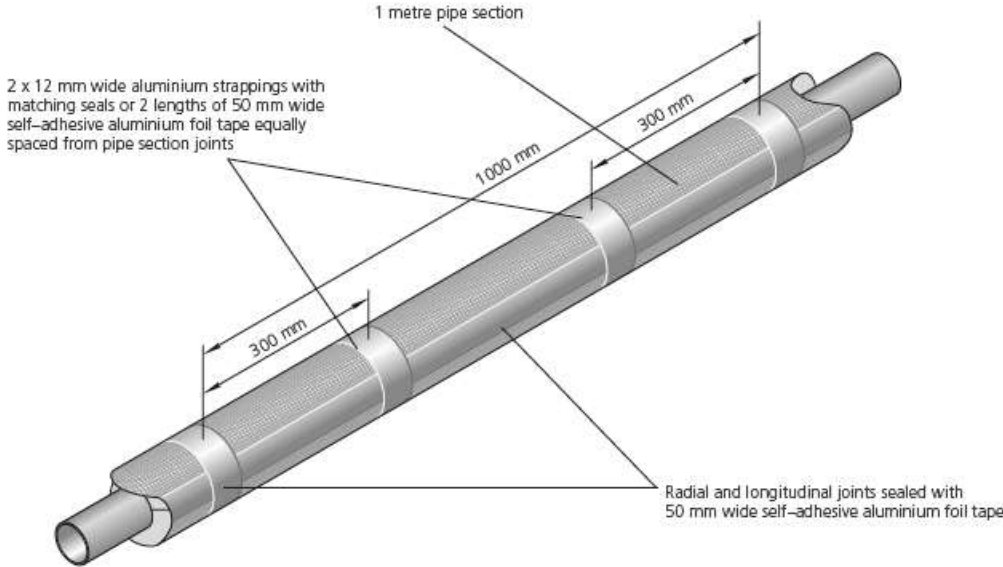
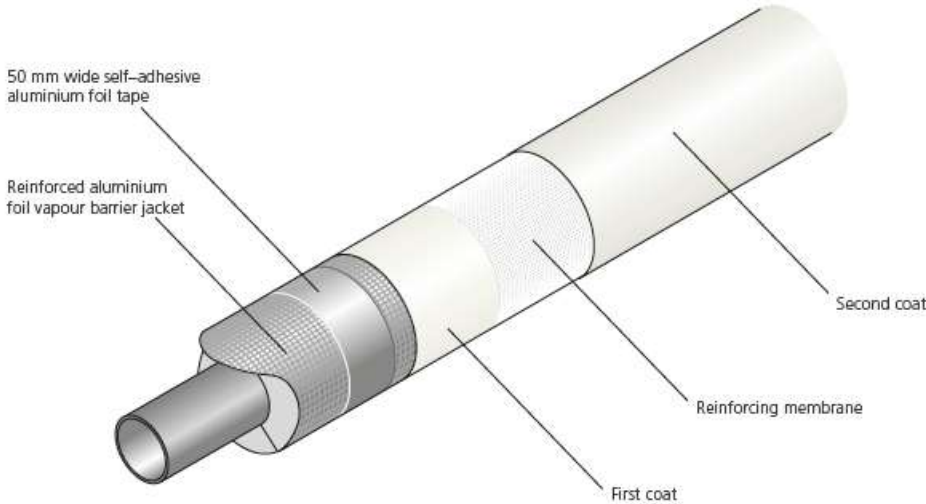

Figure E1: Application of Kooltherm™ FM Pipe Insulation



**3.4.10 Pipe-work Supports**

Refer to General Specification

**3.4.11 Pipe Work Identification**

All isolating and control valves shall be fitted with a propriety made identification label. After the pipe-work insulation is complete, appropriate identification labels shall be fitted at every change of direction etc to comply with BS 1710. Refer to the general specification.

### 3.4.12 System Pressurisation

The entire heating system shall be designed to operate as a closed loop system with the expansion of water taken up by the expansion vessel located in the plant room.

A fill-valve set shall also be installed to fill and maintain the pressure of the heating system. Two non-return valves shall be fitted prior to the system fill valve to protect the mains water supply.

### 3.4.13 Pipe Work Identification

All isolating and control valves shall be fitted with a propriety made identification label. After the pipe-work insulation is complete, appropriate identification labels shall be fitted at every change of direction etc to comply with BS 1710. Refer to the general specification.

#### **VALVES:**

Provide and fit brass draw-off cock, to BS 2879 type A, at the lowest point of the system.

Provide and fit brass gate valve to BS 5154 to cold water feed from expansion tank.

Provide and fit a safety valve and drip pipe as close and practicable to the boiler outlet

#### **CIRCULATION PUMP:**

The circulation pumps to be a variable speed "Grundfos" or similar and approved, as supplied with the boiler and heat pump.

#### **TESTING:**

Provide for testing all pipe work and the system, to the entire satisfaction of the Architect. All leaking pipes or fittings shall be taken out and replaced with new ones, and the whole system tested again. All tests must be attended by the Architect or his representative.

#### **DUCTS FOR SUPPLY PIPES:**

Underground pipes to be not less than 600mm below finished surface. Pipes laid under the surface of the ground and above ground within the building to the point indicated on the drawings or described in this Specification shall be to i.s. 134 with compression fittings for use with such pipes or capillary jointed. Only Triflow or Aluma capillary fitting are permitted under Dublin Corporation waterworks regulations. No filler rod is permitted to be used with capillary joints. Mains water only to be hydrodare heavy duty stamped H.D. with no joints except branch for sink and stop cock which will be located under sink or in a position approved by architect. All concealed pipe work to be insulated.

#### 3.4.14 Wall thermostats and underfloor wiring centre

Wall thermostat shall be Heatmiser Touch V2 digital mains powered thermostats. The contractor shall also supply and install a Heatmiser Neohub to provide integration between the thermostats, WIFI network and the underfloor heating control and wiring centre.

The Neo hub will provide Alexa, Google Assistant and Apple Homekit integration to allow voice control of the heating temperature by room.

Note that the underfloor wiring centres shall be Heatmiser UH6s. Each 230V thermostat shall be wired to these wiring centres.

#### 3.4.15 Pipe-work Supports

Refer to General Specification

#### 3.4.16 Pipe Work Identification

All isolating and control valves shall be fitted with a propriety made identification label. After the pipe-work insulation is complete, appropriate identification labels shall be fitted at every change of direction etc to comply with BS 1710. Refer to the general specification.

#### 3.4.17 System Pressurisation

The entire heating system shall be designed to operate as a closed loop system with the expansion of water taken up by the expansion vessel located in the plant room.

A fill-valve set shall also be installed to fill and maintain the pressure of the heating system. Two non-return valves shall be fitted prior to the system fill valve to protect the mains water supply.

#### 3.4.18 Pipe Work Identification

All isolating and control valves shall be fitted with a propriety made identification label. After the pipe-work insulation is complete, appropriate identification labels shall be fitted at every change of direction etc to comply with BS 1710. Refer to the general specification.

#### **VALVES:**

Provide and fit brass draw-off cock, to BS 2879 type A, at the lowest point of the system.

Provide and fit brass gate valve to BS 5154 to cold water feed from expansion tank.

Provide and fit a safety valve and drip pipe as close and practicable to the boiler outlet

**TESTING:**

Provide for testing all pipe work and the system, to the entire satisfaction of the Architect. All leaking pipes or fittings shall be taken out and replaced with new ones, and the whole system tested again. All tests must be attended by the Architect or his representative

### 3.5 Water Services

#### 3.5.1 Mains Water Supply (MWS)

The existing mains water feed from the existing boiler room shall be extended to the new extension.

The mains water pipework in the building shall be run internally in a non-metallic pipework (insulated) in accordance with IS and as shown on the drawings. All joints and terminations shall be as detailed in the specification.

*(c) A dosing point shall be provided on the mains water supply in the boiler house to facilitate commissioning and disinfection.*

Main water pipework will also be run externally in Medium Density Polyethylene (MDPE).

#### 3.5.2 Cold Water Storage Tanks

A cold water storage tank shall be installed in the plantroom of the new extension. The tank must be format 30 and insulated against freezing conditions. The tank shall be lidded and installed with an overflow/warning pipe to outside.

A drip tray shall be fitted beneath the tank.

#### 3.5.3 Cold Water Services (CWS)

All domestic cold water pipe work shall be manufactured from copper table x tubes complying with IS 238 1980.

All connections to sanitary ware shall be valved.

#### 3.5.4 Domestic Hot Water (DHW)

Hot water to the new extension shall be provided by means of the heat pump located in the plantroom.

To aid water conservation at classroom wash basins, only one tap shall be fitted per basin which shall provide blended hot water for hand washing purposes via approved blending valve.

Where wash hand basins are adjoining or back to back one TMV shall be installed in accordance with manufacturer's instructions to supply the wash hand basins.

All TMV must:

- a. Be suitable for the system head pressure available
- b. Comply with BS EN 1287 for low pressure

- c. Be suitable for under basin installation
- d. Provide safe thermostatic shutdown
- e. Be complete with isolation valves, check valves and easily removable strainers
- f. Have tamper proof temperature adjustment and lockdown.

TMVs serving wash hand basins should be selected to give a flow rate of 0.1 l/s at an inlet head of 1.5m.

All TMVs shall be tested for shut-off in the event of loss of the cold water supply and test certificates included in the handover documentation

All thermostatic mixing valves are to be located such that a maximum dead leg of 1 metre only is achievable on the blended water supply.  
All thermostatic mixing valves (TMV) must be of a TMV3 standard with fail safe lockable thermostatic blending valves limiting the temperature to 42° / 43° Celsius.

All domestic hot water pipe work shall be manufactured from copper table x tubes complying with IS 238 1980.

All pipe work, support hangers and anchors support and control the movement of the various pipes shall be supplied and fitted.

Generally isolating valves to fixtures are not shown on the drawings. However isolating valves and drain cocks shall be supplied and fitted by the sub-contractor to individual or groups of fixtures.

### 3.5.5 Water Boiler

**Supply & install a 30 cup instantaneous water boiler to be mounted on the counter of the staff room.**

### 3.5.6 Water Booster Pump

The mechanical contractor to supply and install a cold water booster pump as per the specification

### 3.5.7 Thermal Insulation

After all hydraulic tests have been carried out on the water services installations the system shall be fully insulated.

As a minimum all pipe-work will be insulated using mineral fibre wool and shall be finished in foil.

The thickness of insulation shall be in accordance with BS 5422; declared thermal conductivity of insulation material shall not be less than 0.035 W/mK at 100°c.

All distribution cold water services pipe work in locations likely to give rise to freezing or condensation shall be appropriately insulated as a continuous vapour barrier.

All distribution hot water services pipe work shall be appropriately insulated.

The insulation shall be of preformed sections of rigid mineral wool incorporating aluminium foil laminate cover and fitted in accordance with the manufacturers instructions. The insulation shall also be applied to all connections, bends, tees and valves.

Proprietary jackets with Velcro fixings shall be used on all valves over 32 mm. Additional taping shall be provided at 2 m intervals on the insulation within the heating centre plant room.

Appropriate colour identification bands and flow directional arrows shall be affixed to all insulated pipe work.

### **3.5.8 Pipe-work Identification**

All isolating and control valves shall be fitted with a propriety made identification label. After the pipe-work insulation is complete, appropriate identification labels shall be fitted at every change of direction etc to comply with BS 1710

### **3.5.9 External Tap Installation**

The mechanical contractor shall supply & install the 2 no. external taps.

## **3.6 Above Ground Drainage**

### **3.6.1 General**

The above ground drainage system shall be installed to suit the new fittings arrangement as identified on the architectural drawings. The mechanical contractor shall provide traps, pipe-work, and fittings to allow the installation of the sanitary ware.

- New uPVC pipework shall be installed for condensate waste removal from the Heat pump, terminating to local waste gully.
- uPVC condensate and defrost waste pipework to be installed from new heat pump condenser to local foul/storm gully.
- New boss connections/manifolds and traps must be installed.

### **3.6.2 Pipework**

Soils and waste shall be generally run in UPVC pipe complying with BS4514 with fittings generally in PVC complying with BS 5255. Joints shall be solvent welded on PVC pipe, but special sockets with synthetic O-rings may be used in some cases, particularly where plastics such as polypropylene are used.

Traps from kitchen sinks and equipment, and from bowl type urinals shall be I brass chrome plated where required.

The above ground drainage system will be designed to comply with BS EN 12056-2:2000 Gravity Drainage Systems Inside Buildings.

The mechanical sub-contractor shall install fire collars to all pipe-work where it breaks through a fire compartment wall. Refer to the Fire Cert Drawings for fire compartments within the building.

### 3.7 Fire Systems

The mechanical contractor shall design, supply, install, test, certify, commission and set to work the complete fire services installation which will include all fire extinguishers, blankets, etc.

Allow for Fire extinguishers in the new extension building.

All location and quantity of extinguishers to be clarified.

Manual firefighting equipment shall comply with IS:290 & IS:291 for the siting, inspection and maintenance of extinguishers and all portable extinguishers and shall be installed throughout the building as specified on the data sheets and in accordance with the following:

- CIBSE Guide E: Fire Engineering
- BS 5306 Part 1 – Fire extinguishing installation and equipment on premises part 1: 1976 (1988): Hydrant systems, Hose reels and foam outlets.
- BS 750 – Underground fire hydrants
- BS 5274 – Hose reels

## 3.8 Control System

### 3.8.1 General

The contractor shall allow for an MCC control panel for the Client.

The Client shall have a controls system comprising self-learning optimum start/ stop control, flow temperature compensation based on internal, external temperatures, motorised valved zone control, maximum internal and external temperature automatic cut out and automatic frost protection as detailed below.

The controls shall include a manual override with run on timer so that heating is available for occasional out of hours use. This shall be located within the Client office or staff room, whichever is nearest to the heating centre plant room. This unit shall be of a type appropriate for its location in terms of aesthetics and size. Industrial housing shall not be acceptable.

Holiday switching shall also be provided on the heating system.

All wording on the control panels shall be agreed with the Client beforehand. Use of terminology such as zone 1, zone 2 on its own shall not be acceptable. The actual zone shall be defined on a colour coded A3 drawing, which shall be laminated, framed and fixed on, or immediately adjacent to the panel on a timber backing screwed to the wall. No abbreviations are to be used on the panel without an explanation in full provided on the drawing.

A remote monitoring and control system indicating the status operation and overriding facilities shall be provided in the Administration Office or staff room whichever is nearest to the heating centre plant room. This shall include a manual override with a selective switch of up to 3 hour run on timer so that heating zones are available for occasional out of hours use. This unit shall be of a type appropriate for its location in terms of aesthetics and size. Industrial housing shall not be acceptable.

The controls system shall comprise of optimum start / stop control and automatic two-stage frost protection and so arranged as to activate the circulation pump at internal temperatures below 5 degrees Celsius and fire the boiler burner when the system return temperature drops to 2 degrees Celsius. The frost protection system shall be independent of the optimum start controllers. All motorised valves shall be controlled to open for frost protection.

The **Complete control system** including sensors, panels and cabling etc. shall be supplied and installed by the **Mechanical Sub-Contractor/Controls Specialist**.

The **Controls Specialist** shall be **Sub-Contracted** to the **Mechanical Contractor**.

The control panel will house all time scheduling clocks, starters and protective gear. All sensing and monitoring devices shall be installed by the controls specialist and shall be wired by the electrical sub-contractor.

Full training shall be given to an appointed member(s) of staff, at THE CLIENT by the controls specialist. Please allow two separate training sessions.

**3.8.2 Low Temperature Hot Water**

The control system shall allow full time scheduling for the new extension heating circuit:

The heating circuit shall be controlled by a Multi Zone 7-day 24-hour time clock. The time scheduling shall allow the user to input various daily on and off times on an annual calendar. Three two port valves for each circuit shall be supplied and installed by the mechanical contractor. The actuator(s) shall be supplied and installed by the control's specialist. Three and two port valves to have manual control handles.

Two-port control valves to be added to class room heating controlled by local wall mount thermostats as per drawing M-100.

The BMS shall control the following heating zones and circuits.

- Heating circulation pumps
- 2-port valves on circulation heating circuits
- 2-port valves on teaching space circuits

Zones shall be independently time and temperature controlled.

**3.8.3 Indication on the Panel**

The following shall be added and indicated on the front of the existing control panel:

The following is to be read in conjunction with the drawings, specifications and points lists.

Heat Pump 1	-	Run/Trip	Hand/Off/Auto Switch
Pump A	-	Run/Trip	Hand/Off/Auto Switch
Heating Circuit 1			
Pump C	-	Run/Trip	Hand/Off/Auto Switch
Domestic hot water pump			
Pump	-	Run/Trip	Hand/Off/Auto Switch

Pressurisation unit  
Booster pump

Allow for a heat meter on the heat pump line (F&R)

---

#### 4. BUILDERS WORK AND PROTECTION

- The Mechanical Sub-Contractor shall be responsible for the protection of all equipment specified in this specification and on the drawings and data sheets, from adverse weather conditions or any other damages that may occur during the construction period.
- In the event of such damage occurring to such equipment, then the Mechanical Subcontractor shall be responsible for making good the repairs to it.
- The Contractor shall allow for co-ordination of builders works. This shall include provision of "Builders Works" details/schedules and supervision of all said works.

#### 5. HANDOVER/ OPERATION AND MAINTENANCE DOCUMENTATION

The Mechanical Sub-Contractor shall handover all other vendor supplied documentation relating to the mechanical installation of this project.

This shall include, but not limited to the following: -

- A full set of "as built" mechanical services drawings.
- Operating and Maintenance manuals.
- Installation Manuals.
- Spare Parts List.
- Calibration/Test Sheets.
- Calculations.
- Commissioning Certificates.
- Completion Certificates.

The Mechanical Sub-Contractor shall include in the contract sum for the issue of three number copies of all the above drawings/documentation.

For details on the preparation of this documentation please refer to the General Specification

#### 6. MILESTONE DATES

- Date of Awarding of Contract: Weeks from receipt of tender
- Commencement Date: Refer to Main Contract
- Completion Date: Refer to Main Contract

## **DATA SHEETS**

**The contractor shall submit full details of all proposed equipment prior to placing an order.**

Data Sheets have been provided to control the quality of the installation.

The Mechanical Sub-Contractor must price the equipment listed in the Datasheets and identify in the Tender Return.

For Alternative refer to the section on Alternatives.

TECHNICAL DATASHEET NO. 01

PIPING AND INSULATION

Service	Nominal Pipe Size	Location	Material	Material Standard	Paint Finish	Insulation Type	Insulation Thickness
Heating System	15-35mm	Internal	Mild Steel	BS1387 Medium	Primed and Painted RAL9101	Foil Backed Fibreglass	25
Heating System	42mm +	Internal	Mild Steel	BS1387 Medium	Primed and Painted RAL9101	Foil Backed Fibreglass	25
Cold Water	15-35mm	Internal	Copper	IS 238	N/A	Foil Backed Fibreglass	25
Cold Water	42mm +	Internal	Copper	IS 238	N/A	Foil Backed Fibreglass	25
Hot Water	15-35mm	Internal	Copper	IS 238	N/A	Foil Backed Fibreglass	25
Hot Water	42mm +	Internal	Copper	IS 238	N/A	Foil Backed Fibreglass	25
Gas	15-50mm	Internal	Mild Steel	BS1387 Heavy	Yellow		
Gas	50mm	External	Polyethylene		Yellow		
Cold Water	65mm	External	Polyethylene		N/A		
Chilled Water	15-35mm	Internal	Mild Steel	BS1387 Medium	Primed and Painted RAL9101	Foil Backed Fibreglass, Vapour Sealed	25
Chilled Water	42mm +	Internal	Mild Steel	BS1387 Medium	Primed and Painted RAL9101	Foil Backed Fibreglass, Vapour Sealed	25

Notes:

1. All external exposed pipework and internal plant room pipework to be insulated in with foil backed fibreglass and shall be aluminium hammer clad

TECHNICAL DATASHEET NO. 02 VALVES

<u>PRODUCT / APPLICATION</u>	<u>SIZE</u>		<u>WATER CHILLED WATER</u>	<u>L.P.H.W.</u>	<u>M.T.H.W.</u>	<u>COOLING WATER</u>	<u>GAS</u>
ISOLATING VALVE	1/2" - 2" 2 1/2" +	B'FLY GATE	Ball Valves INTERAPP D3 M.P. F105	Ball Valves INTERAPP D3 M.P. F105	Ball Valves INTERAPP D3	Ball Valves INTERAPP D3 M.P. F105	RIV 7163 INTERAPP D3N
NON-RETURN VALVE	1/2" - 2" 2 1/2" +		WATTS 1461 M.P. F170	WATTS 1461 M.P. F170	HOLMES 1461 M.P. F170 HT	WATTS 1461 M.P. F170	
STRAINER	1/2" - 2" 2 1/2" +		WATTS 1471 M.P. F185	WATTS 1471 M.P. F185	HOLMES 1471 M.P. F185	WATTS 1471 M.P. F185	
DOUBLE REGULATING VALVE ( DRV )	1/2" - 2" 2 1/2" +		HOLMES BV301 HOLMES BV203	HOLMES BV301 HOLMES BV203	HOLMES BV301 HOLMES BV203	HOLMES BV301 HOLMES BV203	
VARIABLE ORIFICE DRV	1/2" - 2" 2 1/2" +		HOLMES BV321 HOLMES BV223	HOLMES BV321 HOLMES BV223	HOLMES BV321 HOLMES BV223	HOLMES BV321 HOLMES BV223	
COMMISSIONING SET	1/2" - 2" 2 1/2" +		HOLMES BV611 HOLMES BV614	HOLMES BV611 HOLMES BV614	HOLMES BV611 HOLMES BV614	HOLMES BV611 HOLMES BV614	
EXPANSION JOINT	1/2" - 2" 2 1/2" +		THERMOSEL TRB/120 THERMOSEL TRB/121	THERMOSEL TRB/120 THERMOSEL TRB/121	THERMOSEL APS/001 THERMOSEL SAF/002	THERMOSEL TRB/120 THERMOSEL TRB/121	
DIRT & AIR SEPERATOR	3/4" - 1 1/2" 2" - 12"		PNEUMATEX VGA/10 PNEUMATEX VFA/10	PNEUMATEX VGA/10 PNEUMATEX VFA/10	PNEUMATEX VGA/10 PNEUMATEX VFA/10	PNEUMATEX VGA/10 PNEUMATEX VFA/10	
DRAIN-OFF COCK	1/2" - 2"		HOLMES 1481 HOLMES 1482	HOLMES 1481 HOLMES 1482	HOLMES 1481 HOLMES 1482	HOLMES 1481 HOLMES 1482	
LOCKSHIELD VALVE	1/2" - 2"		CIM 70BSL	CIM 70BSL	CIM 70BSL	CIM 70BSL	
AUTOMATIC AIR VENT	10mm		HOLMES 1489	HOLMES 1489	HOLMES 1489	HOLMES 1489	
PRESSURE REDUCING VALVE	1/2" - 2" 2 1/2" +		MALGORANI FIG.143 WATTS DRVD	MALGORANIFIG.143 WATTS DRVD	MALGORANI FIG.143 WATTS DRVD	MALGORANI FIG.143 WATTS DRVD	

Preferred Supplier:

Alma Engineering  
Ravens Rock Road,  
Sandyford Industrial Estate,  
Foxrock  
Dublin  
18

Tel: 01  
2958257  
Fax: 01  
2958259

**TECHNICAL DATASHEET NO. 03**

**CONTROLS**

**Please provide a cost as per the controls description in item 3.10, utilising the following points list**

The recommended controls specialist of use for the works is **EM Comfort Controls Ltd**

**TECHNICAL DATASHEET NO. 04 UNDERFLOOR HEATING SYSTEM**

Underfloor Heating Zones:	Refer to M-100 series drawings for details
Manifolds:	Refer to M-100 series drawings for details
Controlled Temperature:	22 Degrees Celsius
Pipe Spacing:	150mm
Control:	4 port valve and room stats Controlled by Underfloor heating control system

**Notes:**

1. All underfloor heating zones as indicated on the drawings are to be heated by an underfloor heating system, fed from the main plant primary pipework. The underfloor heating system is to be designed and supplied by the specialist underfloor heating contractor and installed by the Plumbing & Heating contractor under his instruction.
2. The system to comprise coils of ultra high-density crosslinked polyethylene pipe laid in the floors and connected to manifolds in the locations specified.
3. The underfloor heating system is to be designed in accordance with DIN 4725, BS EN 1264, or other recognised European standards.
4. The underfloor heating pipework shall be crosslinked by the Engel process and shall be marked as such (PEX-a).
5. The underfloor heating pipework shall incorporate an oxygen diffusion barrier of EVAL bonded to the outside of the PEX pipework, during manufacture.
6. The underfloor heating pipework shall be pigmented with a high opacity pigment to prevent ultraviolet light penetration causing microbiological growth within the circulating water.
7. The underfloor heating manifolds shall be of one piece tubular construction in brass and shall incorporate balancing valves and also flow meters to each circuit, so that correct commissioning and operation of the system can be verified.
8. The underfloor heating system shall, with respect to the whole system (pipe, manifolds, jointing method, ancillary components) and the pipe and jointing system meet the requirements of BS 7291: Class S rating (plastic pipe suitable for connection to an unvented, pressurised heating system).
9. The underfloor heating system shall be covered by an insurance-backed guarantee, provided by the system manufacturer. Specimen guarantee to be provided with tender submission.
10. The specialist underfloor heating contractor shall prepare detailed floor coil layout drawings, for approval, prior to installation of the system.
11. The specialist underfloor heating contractor shall allow for one return visit to site to balance the system, once the main plant has been commissioned.

**TECHNICAL DATASHEET NO. 05**

**CIRCULATING PUMPS**

Pump Ref	Circuit Name	Flow Rate, l/s	External Pressure, kPA	Model No	Notes
P-01	Heating Circuit 1 Pump	0.43	120	Magna3 F	Single Head Variable Speed
P-02	Domestic Secondary pump	0.2	120	1" Bronze	Single Head Variable speed

Notes:

1. Pumps are to be as Grundfos or equal and approved.
2. Pump Head to be checked by contractor prior to ordering and approved by Consulting Engineer.
3. Pump to be selected in mid-range of curve.
4. Pump to be fitted with service valves.
5. All pumps to be linked to the new BMS panel for time and temperature control.

**TECHNICAL DATA SHEET NO. 06 FIRE EXTINGUISHERS AND BLANKETS**

<b>FIRE EXTINGUISHERS</b>			
<b>Number Required</b>	<b>Type</b>	<b>Size</b>	<b>Location</b>
1	Dry Powder	9kg	Boiler Room
3 each	<b>6ltr water and 2kg CO2,</b>		New Extension

Each fire extinguisher shall be supplied with wall mounting bracket and indication signage.

Exact locations of extinguishers to be confirmed on site.

---

**TECHNICAL DATA SHEET NO. 07 2-PORT VALVES**

<b>Actuator Model</b>	<b>Make</b>
HPA2	Danfoss
HPA2	Danfoss
HPA2	Danfoss

**Notes :**

1. All 2-port motorised valves to be installed with Danfoss HPA2 type actuator head as specified or equal and approved.
2. Valves to be submitted to consultant for approval ahead of order and installation.
3. All systems to be installed as per the manufacturer's instructions

**TECHNICAL DATA SHEET NO. 08 HEAT PUMP**

Ref	Capacity (kW)	Model	Make	Refrigerant
OU-01	9	L Series	WH-ADC0509L3E5 + WH-UDG09LE5	R290

**9kw AIO Aquarea High Performance R290 L series Unit**  
**WH-WDG09LE5**  
**WH-ADC0509L3E5**  
**Unvented kit - PAW-G3KIT-1**

Product Information								
Model No:		WH-ADC0509L3E5 + WH-UDG09LE5						
Technical standards and specifications:		EN 14825 / EN 14511 / EN 12102 / EN 12897 / EN 16147						
Parameters:	MEDIUM Temperature Heat Pump	Air-to-water heat pump:		YES	Low-temperature heat pump:		NO	
Parameters:	AVERAGE climate conditions	Water-to-water heat pump:		NO	Equipped with a supplementary heater:		YES	
Test Mode:	Heating / Hot Water	Brine-to-water heat pump:		NO	Heat pump combination heater:		NO	
Item	Symb.	Value	Unit	Item	Symb.	Value	Unit	
Rated heat output (*)	Prated	8	kW	Seasonal space heating energy efficiency	$\eta_s$	144	%	
Bivalent temperature	T biv	-7	°C	Operation limit temperature	TOL	-10	°C	
Rated Seasonal COP of Space Heating	SCOP	3.67		Heating water operating temperature	WTOL	55	°C	
Declared capacity for heating for part load at indoor temperature 20°C and outdoor temperature Tj				Cdh (**)	Declared coefficient of performance for part load at indoor temperature 20°C and outdoor temperature Tj			
Tj = -7°C	Pdh	7.10	kW	1.00	Tj = -7°C	COPd	2.28	-
Tj = +2°C	Pdh	4.30	kW	0.99	Tj = +2°C	COPd	3.60	-
Tj = +7°C	Pdh	2.80	kW	0.98	Tj = +7°C	COPd	4.72	-
Tj = +12°C	Pdh	3.20	kW	0.97	Tj = +12°C	COPd	6.17	-
Tj = T biv	Pdh	7.10	kW	1.00	Tj = T biv	COPd	2.28	-
Tj = TOL	Pdh	7.50	kW	1.00	Tj = TOL	COPd	1.98	-
					Annual energy consumption	Q <sub>HE</sub>	4499	kWh
Parameters:	LOW Temperature Heat Pump	Air-to-water heat pump:		YES	Low-temperature heat pump:		NO	
Parameters:	AVERAGE climate conditions	Water-to-water heat pump:		NO	Equipped with a supplementary heater:		YES	
Test Mode:	Heating / Hot Water	Brine-to-water heat pump:		NO	Heat pump combination heater:		NO	
Item	Symb.	Value	Unit	Item	Symb.	Value	Unit	
Rated heat output (*)	Prated	8	kW	Seasonal space heating energy efficiency	$\eta_s$	190	%	
Bivalent temperature	T biv	-10	°C	Operation limit temperature	TOL	-10	°C	
Rated Seasonal COP of Space Heating	SCOP	4.84		Heating water operating temperature	WTOL	55	°C	
Declared capacity for heating for part load at indoor temperature 20°C and outdoor temperature Tj				Cdh (**)	Declared coefficient of performance for part load at indoor temperature 20°C and outdoor temperature Tj			
Tj = -7°C	Pdh	7.1	kW	0.99	Tj = -7°C	COPd	2.83	-
Tj = +2°C	Pdh	4.3	kW	0.99	Tj = +2°C	COPd	4.89	-
Tj = +7°C	Pdh	2.8	kW	0.97	Tj = +7°C	COPd	6.21	-
Tj = +12°C	Pdh	3.3	kW	0.97	Tj = +12°C	COPd	7.45	-
Tj = T biv	Pdh	8.0	kW	1.00	Tj = T biv	COPd	2.57	-
Tj = TOL	Pdh	8.0	kW	1.00	Tj = TOL	COPd	2.57	-
					Annual energy consumption	Q <sub>HE</sub>	3417	kWh

Notes :

1. Heat Pump shall be Ideal as specified or equal and approved.
2. Heat pumps shall operate on R32 refrigerant.
3. Heat pump shall be monobloc type heat pumps.
4. Heat pump to be installed with anti-vibration feet.
5. Heat pumps shall be installed as per the manufacturer's instructions.



**Technical Datasheet No: 10****Water Storage Tank**

Ref:	CWT-01
Quantity:	1 x Multiboost
Location:	Refer to M300
Storage Capacity:	200 Litres
Tank Model:	Format 30
Ball Valve,	Copper ball valve to be provided and enclosed in a ball valve housing with access hatch above level of cover.
Overflow:	35mm over flow to be provided
Air Venting:	50mm Tank Filtered air vent with to be installed

**Notes:**

1. Tank and accessories must comply with BS6700 and County Council requirements.
2. Tank to be insulated and finished to Format 30.
3. Low level valved drain to local gulley to be provided by mechanical contractor.
4. Tank will need to be cut in-situ by mechanical contractor for installation of pipework connections.
5. All pipework to be adequately supported
6. Mechanical contractor to coordinate with Main Contractor the construction of tank base. Base to be installed to tank manufactures instructions.

**Technical Datasheet No: 11**

<b>Reference:</b>	Water Boiler
<b>Location</b>	Staff Room
<b>Quantity</b>	1
<b>Storage</b>	Instantaneous
<b>Electrical power , kW</b>	6
<b>Electrical Supply</b>	50Hz Single Phase
<b>Manufacturer</b>	ZIP
<b>Model No</b>	Aqua boiler
<b>Expansion</b>	

Technical Datasheet No: 12 Extract Fans

Fan Ref	Location	Description	Quantity	Air Flow, L/s	External Static Pressure, Pa	Power	Model	Comments
EF-01	Ensuite Toilets	Extract Fans	AS PER DWG		40	1PH 230V 50Hz	As per drawings	Fans to be connected to PIR Sensor c/w connection to external BVK louvre and run on timer

Notes :

1. All extract fans are to be suitably protected for external mounting where applicable.
2. All fans to be supplied by:  
Systemair Tel: 01 8628033

---

**TECHNICAL DATASHEET NO 13: ENERGY METERS**

Quantity: AS PER DRAWINGS (SUITABLE FOR heat meters)

Make: Sontex

Location: Plant Room

Model: Supercal 531

Comms: BACnet, ModBus and LON

Flow meter: Superstatic 440

**TENDER RETURN FORMS**

**Please complete below FOT and complete in full the accompanying pricing document for the mechanical works.**

---

**SECTION A: FORM OF TENDER**

**FORM OF TENDER**

**For the**

**MECHANICAL BUILDING SERVICES INSTALLATION**

**TO:**

I/We, the undersigned, undertake to execute the works described in the Specification and Drawings for the **Fixed Price Sum** of

.....  
.....  
.....

€ .....

The foregoing sum will be subject to VAT. The individual VAT rates and corresponding amounts are € .....

The total VAT Amount is € .....

I/We, the undersigned, are prepared to execute the works in conformity with the building programmes; which will be determined subsequent to the placing of the Main Contract, and complete the works within the time specified for the completion of the Main Contract.

I/We, the undersigned, are prepared to enter into an Agreement within the terms of the Main Contract Conditions.

I/We, the undersigned, agree that if we are nominated as Contractors for the sub-contract works and shall sign a Collateral Warranty with the Client and that we shall furnish a Bond as specified.

Signed: .....

For and On Behalf of .....  
.....

Date: .....

---

**SECTION C: SCHEDULE OF MATERIALS COSTS AND  
ALTERNATIVES**

---

**SCHEDULE OF MATERIALS PRICES:**

**The Tenderer must give below basic prices of all materials used in making up their tender.**

(This page is to be copied or duplicated as required)

Material	Manufacturer	Catalogue No.	Basic Price ( € )	Delivery Time
----------	--------------	---------------	----------------------	---------------

Signed

For and on Behalf of

Date

**SCHEDULE OF ALTERNATIVE MANUFACTURERS AND COST REDUCTIONS**

(This page is to be copied or duplicated as required)

Item	Specified Manufacturer	Alternative Supplier Proposed	* Credit If Accepted ( € )
------	---------------------------	----------------------------------	----------------------------------

\* The credit is deemed to include labour,  
profit and overheads but exclude builders  
discount and VAT

Signed .....

For and on Behalf of .....

Date: .....

**ISSUE REGISTRATION:**

**Project Title: ACDAL Extension**

**Project No: 26K27**

Rev	Date	Purpose of Issue/Nature of Revision	Prepared by	Issue Authorised by
T1	June 2026	Tender	AB	AB

*This document takes into account the particular instructions and requirements of our Client. It is not intended for and should not be relied upon by any third party and no responsibility is undertaken to any third party.*

**Ronan Meally Consulting Engineers Limited**  
1 City Wall, James Street,  
Kilkenny  
Ireland  
Telephone (056) 7795428  
Facsimile (056) 7795427  
Email: info@rmce.ie